

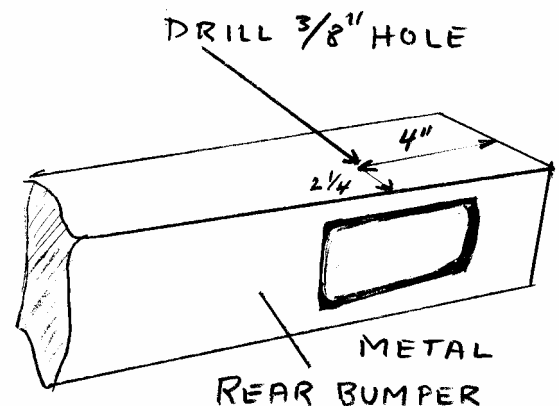

INSTALLATION OF DELTA BACK-UP LIGHTS Hummer H2 P/N 01-4329-50X

1. Open rear door to allow removal of the center plastic bumper cover.
2. Proceed to remove plastic bumper cover by prying the pins from the center of the nylon anchors and then removing them.
3. Remove the two plastic corner bumper covers the same way described above.
4. Using the supplied template, place the template in the recessed portion of the plastic bumper cover, right and left, and trace the shape to be cut.
5. Cut an opening on the inside of the traced shape.
6. Drill $3/8$ " holes in the metal bumper, one on each side – 4" from the side of the bumper and $2\frac{1}{4}$ " from the face of the rear bumper.
7. Mount the lights onto the metal rear bumper.
8. Plug in the male connector leading from the white wire of your back-up lights into the respective red wire lead.
9. Plug in the male connector leading from the black wire of your back-up lights into the respective black ground wire lead. Ground each light using a self-tapping screw (provided) to any metal surface of the bumper or frame.
10. Locate the wire leading from each factory back up light. Using snap-lock connector, tap each red wire leading from the back up light into your factory reverse light wire.
11. Reinstall the corner bumper covers followed by the center cover.



Your backup lights will now operate each time you switch your gear in the Reverse (R) position.



INSTALLATION OF DELTA BACK-UP LIGHTS Hummer H2 P/N 01-4329-50X

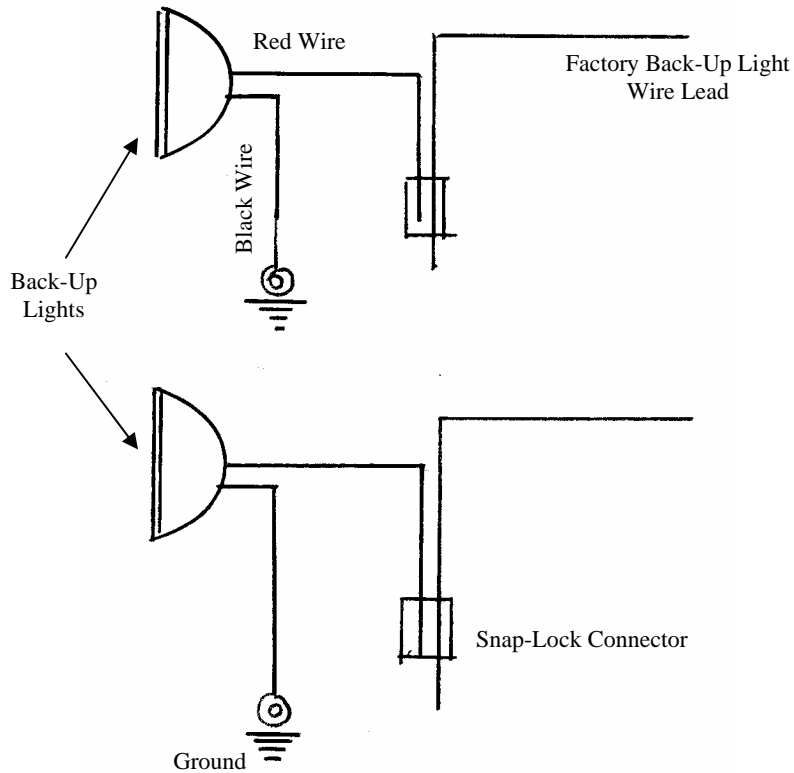

CONTENTS:

- 2 Lights
- 1 Template
- 2 Snap Lock Connectors
- 4 Heat Shrink Tubing
- 4 Cable Ties
- 2 Red Wire Leads (5')
- 2 Black Wire Leads (3')
- 2 Self-Tapping Screws

