



550 Series H.I.D. High/Low Light System WIRING & INSTALLATION INSTRUCTIONS



DELTA TECH INDUSTRIES, LLC • (714) 577-8028



550 Series H.I.D. High/Low Light System WIRING & INSTALLATION INSTRUCTIONS

DELTA TECH INDUSTRIES, LLC • (714) 577-8028

- 1. Mount H.I.D. Lights** on bumper or grille guard using 5/8" mounting shanks.
- 2. Mount Ballasts & Control Units** using provided adhesive pads. Make sure the surface is smooth (not curved or rough) and clean (with alcohol for best results). Use the provided mounting bracket and screws if there is no suitable location for adhesive pad.
- 3. Mount Relays** in close proximity to the positive posts on the battery.
- 4. Plug Power Cable** connectors (OUT, on the Ballast) into the Black and Red leads from the lamp. These are the power source for the H.I.D. Burner. They are shaped to only fit the correct way.
- 5. Plug The High/Low Control Unit** into the square connector at the lamp.
- 6.** Plug the other terminal from the Hi/Lo Control Unit into **HID Harness**
- 7.** Connect **H4 Adapter** to Wire leading from the **Splitter** terminated with 3-prong H4 type plug
- 8.** Connect yellow wire from H4 Adapter to yellow wire lead and on to #87 prongs on a High Beam Relay
- 9.** Repeat steps 1-5 for the other HID light and connect yellow wire lead to prong #87A on the High Beam relay
- 10.** Connect blue wire from H4 Adapter to a yellow wire leading to prong #87 on the **Low Beam Relay**, repeat the same step for the other light connecting it to prong #87A on a Low Beam relay.
- 11.** Ground each black wire leading from the adapter to any metal surface
- 12.** Connect red wire lead from each **HID Harness** to positive post on the battery
- 13.** Connect black wire lead from each HID Harness to ground
- 14.** Ground each relay using 6" black wire leads
- 15.** Energize each relay with a fused red wire lead from prong #30 on the relay to a positive post on the battery
- 16.** Lead blue wire lead from #85 on each relay to a 2-way Hi/Lo toggle switch
- 17.** Energize the switch by connecting middle prong on the switch to a selected "Hot" wire under the dash with a supplied snap-lock connector

WIRING KIT CONTENTS:

- (2) H.I.D. Lights
- (2) Ballasts
- (2) High/Low Control Units
- (2) Relays
- (2) H.I.D. Harnesses
- (2) H4 Adapters
- (2) Sealed Fuse / Red Wire Sets
- (4) Yellow Wire Leads
- (1) Red Wire Lead
- (2) Blue Wire Leads
- (2) Black 6" Wire Leads
- (1) Snap-Lok™ Connector
- (6) Cable Ties
- (1) 2-way (High/Low) Switch
- (2) Hardware Sets



550 Series H.I.D. High/Low Light System WIRING & INSTALLATION INSTRUCTIONS

DELTA TECH INDUSTRIES, LLC • (714) 577-8028

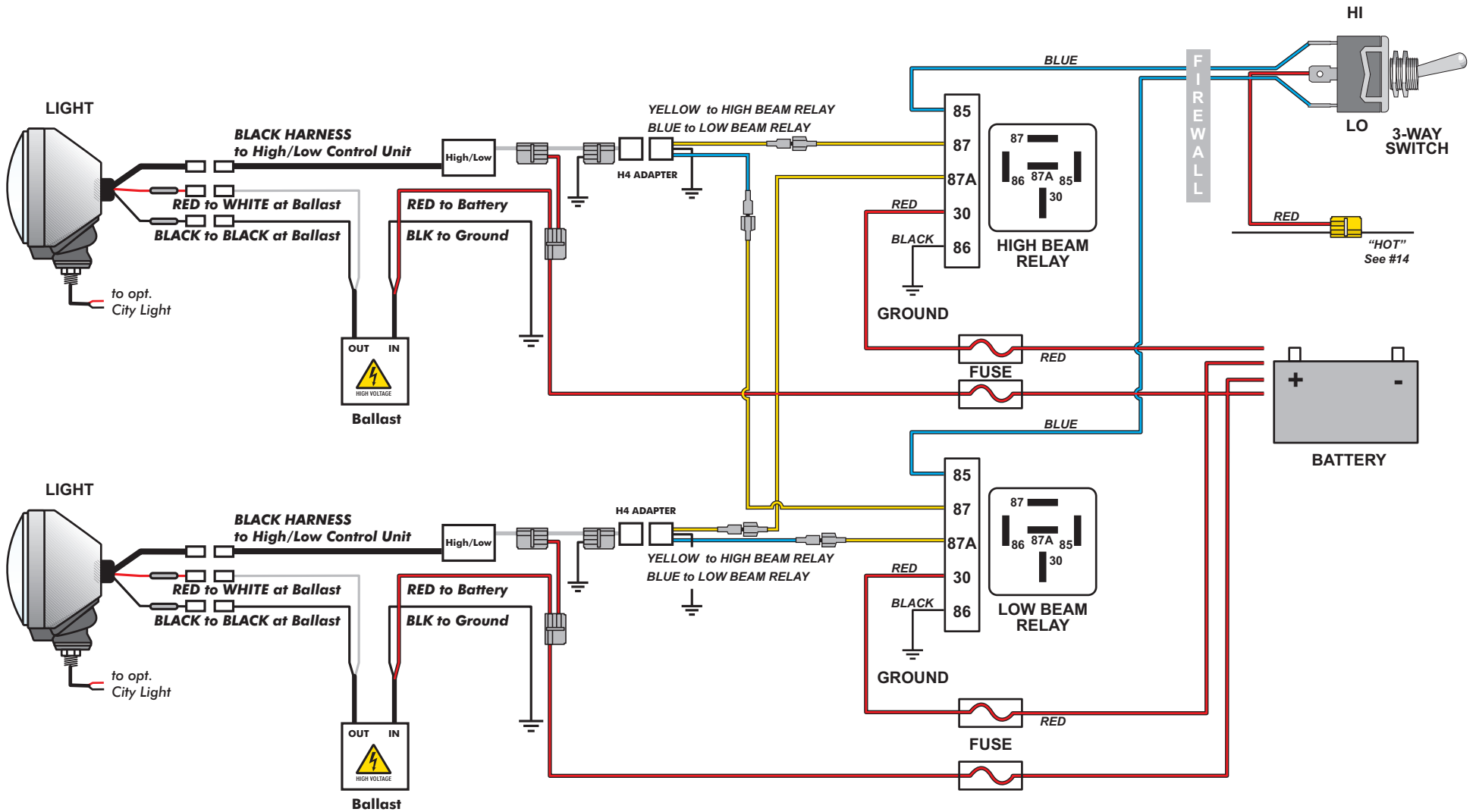



550 Series H.I.D. High/Low Light System WIRING & INSTALLATION INSTRUCTIONS

OPTIONAL "CITY LIGHTS" WIRING

AUXILIARY PARKING LIGHTS:

Tap a line leading from the prong of the miniature bulb into your existing parking light line. The other prong should be grounded.

DAYTIME RUNNING LIGHTS:

Tap a line leading from one prong of the miniature bulb into an ignition switch line that is hot with the ignition "ON" such as the heater fan. Or a line that is hot when the ignition is switched to "ACC" such as the radio.

AUXILIARY DIRECTIONAL LIGHTS:

First, change the miniature bulbs inside your Delta® lamps to a DOT-legal, amber colored equivalent type bulb. Then tap each light into its respective existing directional light line.

(Order our pre-assembled "City Light" Harness, Part No. 05-2000-37)

SAFETY PRECAUTIONS:

Use common sense.

Wear eye protection when working near the battery. Battery vapors are explosive and battery acid can blind you, disfigure you, or kill you as well as mess up your paint job.

Disconnect the battery when working on electrical components to avoid shorting out expensive computer chips, ruining your new lights or melting the wires you have in your hands.

Use proper electrical tools and connectors (duct tape is not a proper electrical connector).

When running wires, follow factory wiring looms when possible. Especially when pulling through the firewall. Wires through a freshly drilled hole in the firewall, or any unprotected passage through sharp metal, will eventually know its way through the plastic coating. If you cannot follow a wiring loom buy a rubber grommet or seal the wire into the hole with silicone caulk.